

IAC-13-A2.3.3

**EJECTION AND RECOVERY SYSTEM FOR CUBESAT SIZED EJECTABLES
ON SOUNDING ROCKETS**

**Nathan Donaldson^{*}, Thomas Parry[†], Thomas Sinn[‡],
Daniel Garcia Yarnoz[§], Christopher Lowe^{**}, Ruairidh Clark^{††}**
University of Strathclyde, Glasgow, UK

Many sounding rocket experiments have the requirement to be free flying due to their size or the required precision of their measurements which would be falsified by other experiments on-board the same sounding rocket. This paper outlines the ejection and recovery system that was flown on the sounding rocket REXUS13 in May 2013 as part of the StrathSat-R experiment. The ejection system consists of two free flying units (whose dimensions are that of a one unit cube satellite) ejected from the side of an experimental module. The cubes are ejected via compressed springs which are constrained during launch by a stainless steel cable that holds the hatches in place. A pyro cutter is then used to sever the steel cable at apogee in order to release the cubes in free space. During descent, a recovery system consisting of a parachute, a GPS receiver, a Globalstar transmitter and a radio beacon is activated and used to locate the two cubes after impact. The parachute is automatically released at ~5km enabling the GPS receiver to locate the falling cubes and transmit their positions over the Globalstar satellite system and the radio beacon to the ground station. This paper will present the mechanical design of the ejection system and the electronic design and component selection of the recovery system.

I. ACRONYMS

ASCL	Advanced Space Concepts Laboratory	RXSM	REXUS Service Module
		PCB	Printed Circuit Board
COTS	Commercially Off The Shelf	SODS	Start of Data Submission
DLR	Deutsches Zentrum für Luft- und Raumfahrt (German Aerospace Center)	SOE	Start Of Experiment
EEE	Electronic & Electrical Engineering Department	SNSB	Swedish National Space Board
ESA	European Space Agency		
IMU	Inertial Measurement Unit		
FFC	Flexible Flat Cable		
MAE	Mechanical and Aerospace Engineering Department		
MCU	Microcontroller Unit		
LO	Lift Off		
OBDH	On-Board Data Handling		
REXUS	Rocket-borne Experiments for University Students		
RF	Radio Frequency		
RMS	Root Mean Square		

II. INTRODUCTION

A sounding rocket is a ballistic research rocket carrying scientific instruments on a suborbital flight to an apogee between 50 and 1500km altitude [1]. Sounding rockets can be used for a variety of research topics ranging from atmospheric science and microgravity research to technology demonstrations. The REXUS program [2] of the German Aerospace Centre (DLR), the Swedish National Space Board (SNSB) and the European Space Agency (ESA) gives up to ten student teams from across Europe the possibility to launch their experiments onboard a REXUS sounding rocket to up to 100 km altitude. Every year two REXUS rockets are launched from the Swedish space centre Esrange close to Kiruna, Northern Sweden. Most of the scientific experiments are located within the experimental modules of the sounding rocket. Some of these experiments require free flying units due to the fact that the experiment has to be conducted in free space or that measurements from different atmospheric locations shall be taken during re-entry. Over the last three years, different systems to eject free flying objects from sounding rockets have been proposed and flown. For the REXUS sounding rockets, there exist two different locations from which to release an ejectable: from under the nosecone in direction of the flight or from one of the experimental modules ejecting to the sides. The REXUS12 experiment, Suaineadh [3],

^{*} MAE, University of Strathclyde, UK,
nathan.donaldson@strath.ac.uk

[†] EEE, University of Strathclyde, Glasgow, UK,
thomas.parry@strath.ac.uk

[‡] ASCL, MAE, University of Strathclyde, Glasgow, UK,
thomas.sinn@strath.ac.uk

[§] ASCL, MAE, University of Strathclyde, Glasgow, United Kingdom,
daniel.garcia-yarnoz@strath.ac.uk

^{**} ASCL, MAE, University of Strathclyde, Glasgow, UK,
christopher.lowe@strath.ac.uk

^{††} MAE, University of Strathclyde, UK,
ruairidh.clark@strath.ac.uk

ejected a $\text{Ø}20 \times 20 \text{ cm}^3$ free flying unit from the nosecone by using a compressed wave spring and an ejection barrel to secure and guide the ejectable. The Suaineadh ejectable did not have any recovery system with the exception of a radio beacon. An experimental module ejection system was used by REXUS11's RAIN team [4] and REXUS13's MUSCAT team [5]. RAIN ejected two cylindrical free flying units followed by MUSCAT ejecting four spherical units the year after. All of the RAIN and MUSCAT free flying units were equipped with a parachute, a GPS receiver, a Globalstar transmitter and a radio beacon. All of their ejectables were found by the recovery helicopter in November 2012 (RAIN) and May 2013 (MUSCAT). The ejection and recovery system described in this paper is from the REXUS15/16 experiment StrathSat-R [6] which was previously flown on REXUS13 but did not eject at apogee due to a procedural error. The StrathSat-R experiment is designed to deploy two cube satellites from the REXUS sounding rocket at around 90 km and record the deployment behaviour of two different inflatable structures.

III. MECHANICAL DESIGN

The mechanical design is divided into three main subsystems; two ejectable CubeSat-like structures and the ejector assembly that remains on-board the rocket. The ejector assembly provides the required structural support, retention and ejection mechanisms for the ejectables and also comprises two camera mounts and cameras for recording video footage of the flight. The experiment structure is largely machined from Aluminium 6082-T6. Other notable components include the PCBs in each sub-section with associated electronic components, the aluminium machined elements and the Tecanat polycarbonate ejector rail covers and camera windows, which protect the interior of the ejection system and cameras from the external environment.

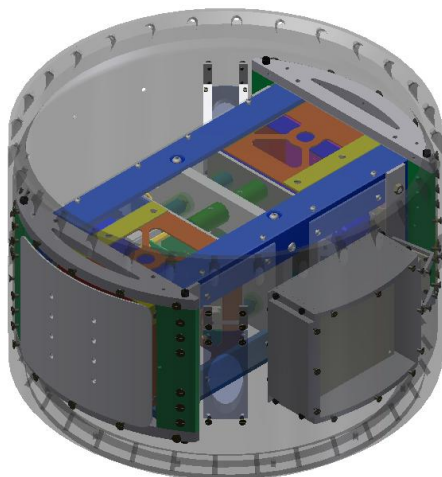

Figure 1: CAD of Experimental Module

The loads experienced during launch, 12 g RMS., are transferred to the Experiment Module skin via the D-Brackets and Hatch Reinforcement Blocks. Upon deployment of the ejectables, the experiment is left open to the elements. To prevent excessive ingress of debris during the landing phase, Tecanat snow covers are incorporated into the design (see Figure 1 for a 3D CAD representation of the full experimental module).

The Ejector Assembly is shown in Figure 2 and comprises the following components: Base Plate Assembly, Spring Platform Assemblies (x2), L-brackets (x4), Ejection Springs (x8), Spars (x4) and Snow Covers (x5)

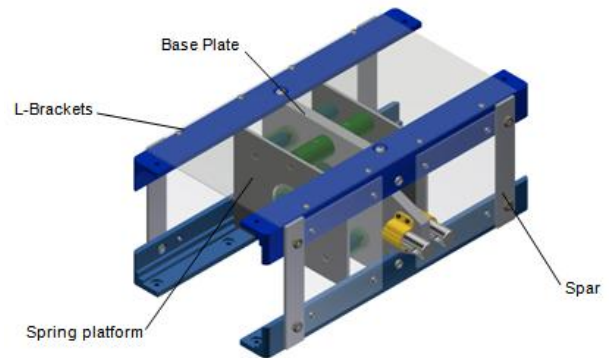

Figure 2: Ejector CAD model

The Base Plate Assembly provides structural support to the ejector, with Spring Tubes on both sides of the plate, four of which are used to guide the Ejection Springs (see Figure 2). A hole is present in the centre of the plate through which electrical cables connect the ejectables to the electronics in the ejector assembly. On one side of the Base Plate there is an extension which provides a platform onto which the pyro-cutters are mounted.

The two additional spring tubes which are not used as guides house a long pin inserted through a vertically aligned series of holes on their sides during assembly. This acts as an assembly aid, maintaining compression of the ejection springs until assembly of the experiment is complete, thereby allowing the ejection springs to take up any slack in the system. These pins also act as a safety feature to guarantee that no person is in danger of being injured by an accidental ejection.

To transfer force from the ejection springs evenly across the face of the ejectable module a spring platform is used. The ejectable modules sit on this spring platform, seen in Figure 2, and are pushed in opposite directions once the cable is severed.



Figure 3: Base Plate Assembly with Retention Tubes

The Ejection Springs provide the force necessary to jettison the hatch assembly and ejectable modules, at a velocity greater than 1 m/s from the rocket. There are four springs per CubeSat, each of which has a spring rate of 0.7 N/mm, and is compressed by 35.7 mm during launch. The ejection velocity can thus be estimated as 1.74 m/s.

The L-brackets form part of the ejector rails for the deployment of the modules. The purpose of the L-brackets is to function as guides for the ejectable modules to slide along during ejection. In addition, the L-brackets provide the structural support necessary for the ejectable modules during launch.



Figure 4 – L-bracket

The L-brackets are rigidly held in place, with a low tolerance fit, by the D-brackets at either end. This is key to the design as any significant deviation in position of the L-brackets may cause the ejectable modules to become jammed during ejection.

III.I Ejectables

The two ejectables are based on a CubeSat architecture with outer dimensions of 13x11x10 cm³. On the electronic side, the ejectables house a data handling, power and tracking board with a GPS receiver, a Globalstar transmitter and an RF-beacon. The electronics will be described in detail in section IV.

To decelerate each ejectable, a parachute is housed in an enclosed section, external to the payload section. The available payload volume in each module is 11x10x4 cm³.

Cube Architecture

The ejectable Modules are segmented into three regions; the subsystem electronics, the deployable payloads and the parachute and antenna housing. The main structure is composed of four Aluminium 6082-T6 panels, held together with L-shaped brackets (Figure 5). A bulkhead is included to separate the electronic components and the deployable payload.

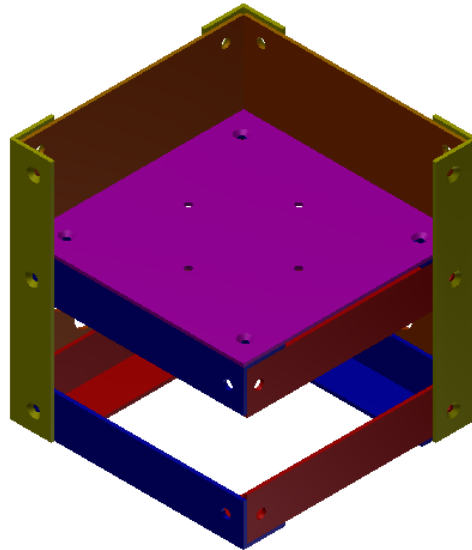

Figure 5: Interior support frame arrangement

A loosely fitting lid panel is incorporated in order to enclose the deployable payload during launch, but is free to jettison upon ejection of the modules (Figure 6). It is held in place during launch by the compressive forces between the Hatch Assembly and the Spring Platform.

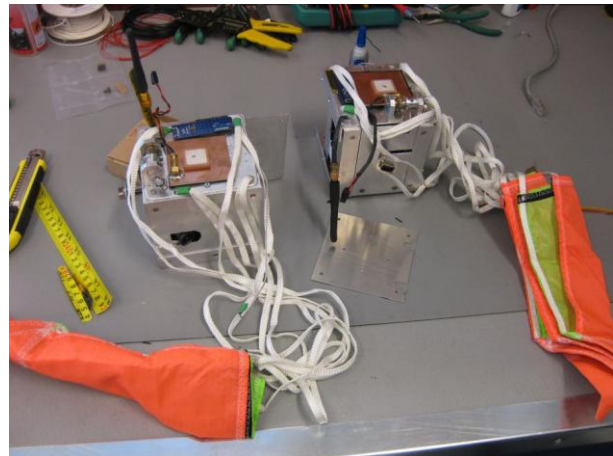

Figure 6: Fully assembled cube satellite modules

The external L-brackets are important as they fit in the guide rails, aiding the ejection of the modules upon release of the retention system.

Mounting the electronics within the ejectable modules is achieved by strapping the two SAFT batteries securely against the plate that separates the payloads from the electronics enclosure. The three evenly spaced PCBs fill the remainder of the space in the electronics enclosure, where they are separated by a PCB spacer in each corner. Figure 7 highlights these key components on board the modules.

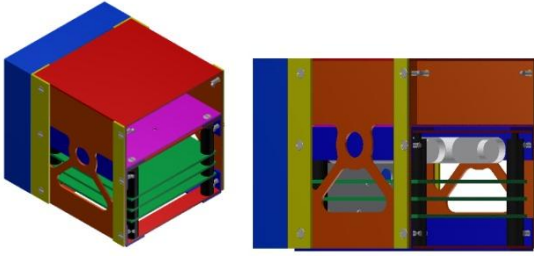

Figure 7: PCBs and batteries within ejectable module

Parachute System

During descent, the ejectables need to be decelerated by a parachute. This is to facilitate the survival of the electronics responsible for locating the modules following their descent and storing experimental sensor data. The slower descent also helps the GPS system to get a fix and allows for the radio transmissions from the ejectables to be received by the ground station.

A cross type parachute was selected; as such parachutes have a very small lateral profile, allowing a high resilience to side winds. This feature is beneficial as it minimises the effects of cross winds on the trajectory of the ejectables during the descent.

A Top Flight Recovery Ultra-X Type parachute with a 24" diameter was selected.

Calculations were conducted to assess the maximum size of parachute and cord that could be accommodated inside the planned enclosure.

Taking the density of the parachute fabric as 0.06 g/m^2 , assuming a packing efficiency of 60% and taking the free internal volume of the parachute enclosure to be $2 \times 10^{-4} \text{ m}^3$, an approximate parachute mass of 0.1386 kg was calculated.

This in turn was used to assess the area and hence, the radius, of the parachute that could be packed into the enclosure (assuming that the cross parachute would achieve a hemispherical shape following deployment). These were found to be 2.3101 m^2 and 0.4288 m respectively.

Using a drag coefficient calculated through experimentation by the KTH SQUID team [7] of REXUS09/10 and the RAIN team [4] of REXUS11/12

of 0.9 for this type of parachute, the final terminal velocity of the modules was calculated as being $\sim 6 \text{ m/s}$.

It was assumed that at some point during the descent of the ejectables terminal velocity would be reached, when the drag force exerted by the parachutes would match the weight of the ejectables, causing a steady state descent affected only by the variances of air density and gravity with altitude. As such, the calculations mentioned above, which deal with sea level values of air density and gravitational acceleration, are only valid for the terminal velocity of the modules immediately before touching down.

A further simulation of the ejectable's descent was carried out using a Python script which utilised an iterative calculation scheme and the 1976 US Standard Atmosphere to arrive at a more accurate estimate of the relevant terminal velocity. These calculations (the results of which are shown in Figure 8) proved difficult to fully validate, but did allow a revised estimated ground impact velocity of $\sim 11 \text{ m/s}$, which was incorporated into future design considerations as a new 'worst case'.

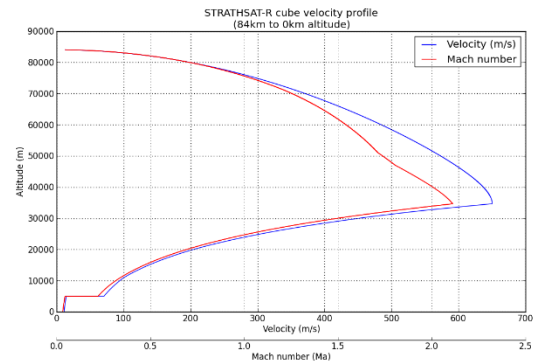

Figure 8: Cube velocity profile

Lid Ejection System

The lid ejection system is composed of a detachable lid under which the parachute sits. The RF antenna itself is utilised as the ejection mechanism with a bent tape measure strip used to apply a restoring force that pulls the antenna upright, as seen in Figure 9, which has the added benefit of assisting ejection of the lid. This plate also houses a patch antenna used in conjunction with the radio beacon to provide the ejectable's location during and after descent.

A tensioner has also been added in order to allow external tightening of the retention cable, holding the lid in place prior to release (through aligned holes in the lid). The parts used in this assembly are available COTS. The worm gear is composed of 214 M15 steel while the pinion gear is composed of 303S21/3 stainless steel.

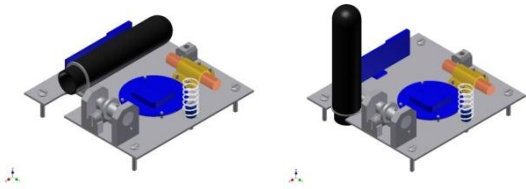

Figure 9: Parachute deployment mechanism without enclosure lid (showing both spring deployed and stowed RF beacon)

III.II Retention System

The Ejectable Modules are retained within the Ejector Assembly by a 1 mm diameter Steel cable, which passes through each of the Hatch Blocks and prevents premature jettison.

At the point of separation, two TRW pyrocutters provide redundancy in severing the cables, resulting in ejection of the hatch assemblies and ejectable modules through force applied by the ejection springs. This design requires three wires to be fed through and cut by the TRW cutters. A single wire looped multiple times is used to constrain both ejectable modules. The wire loops through the tensioner and attaches to the opposite reinforcement frames, at either end. A stopper is attached to one thread of wire inside the hatch enclosure. This stopper is not acted on while the setup is tensioned but ensures that the wire escapes with the hatch after ejection. This setup can be seen in Figure 10. The stopper used for this test was a screw tightened wire grip.

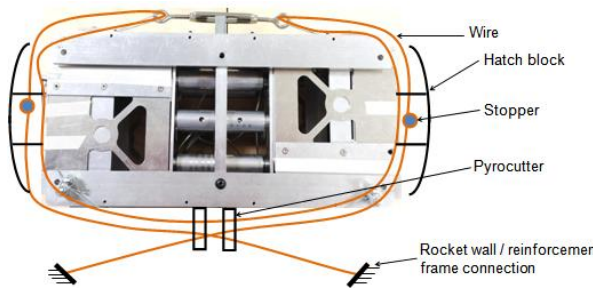

Figure 10: Retention System (pre-deploy) – some components removed for clarity

One end of the cable is secured inside the hatch with a wire clamp. The clamp is located within the hatch, thereby preventing the wire from escaping the hatch through the small hole.

Retention Assembly Procedure

1. Push Spring Platforms toward the Base Plate until Ejection Springs are fully compressed.

2. Insert Retention Pin through Retention Tube holes to retain Spring Platform in this position.
3. Insert Ejectable Modules into Ejector Assembly.
4. Clamp cable to one side of rail assembly and thread through both Pyros (secure using two wire clamps).
5. Thread cable through holes in first Hatch Block (via holes in Hatch Reinforcement Blocks as guides) and into opposite side of module.
6. Loop the wire through the eye of a miniature turnbuckle.
7. Thread the wire back through the same Hatch Block (via holes in Hatch Reinforcement Blocks as guides).
8. Thread wire through pyros once again.
9. Repeat steps 5, 6, 7 and 8 for other side of assembly (using same cable).
10. Take up slack in system and ensure loose components are correctly positioned.
11. Secure end of wire to rail assembly using a pair of wire clamps.
12. Attach wire clamps to wire threaded through Hatch Blocks (attach to one wire only as clamping both wires will prevent a successful ejection) Rotate the turnbuckle until wire is sufficiently taught.
13. Attach Hatch Covers to Hatch Blocks and align to fit module exterior. Tie turnbuckle to Ejection Assembly so that it remains in place post ejection. Use cable ties to ensure turnbuckle does not work loose during launch.

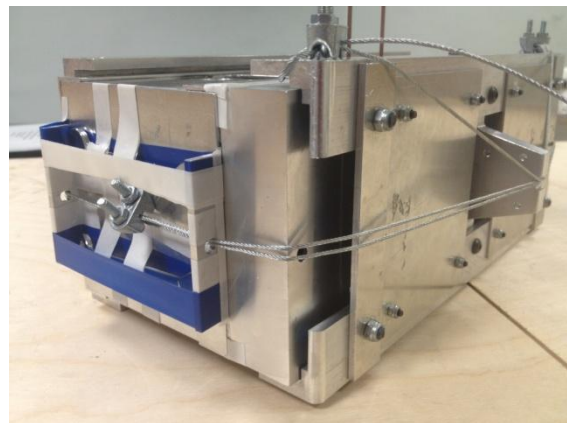

Figure 11: Design revision ejection setup

IV. ELECTRONIC & SOFTWARE

The electronic system is based around a data handling PCB that is replicated for use in both of the ejectable modules, as well as the electronics box which stays on-board the rocket experimental module. Each of the ejectables comprises an additional tracking PCB with Globalstar satellite and VHF transmitters. Each independent subsystem (data handling and tracking) being located on its own PCB is both convenient for design and a necessity as high speed digital circuits are better placed away from sensitive RF circuits.

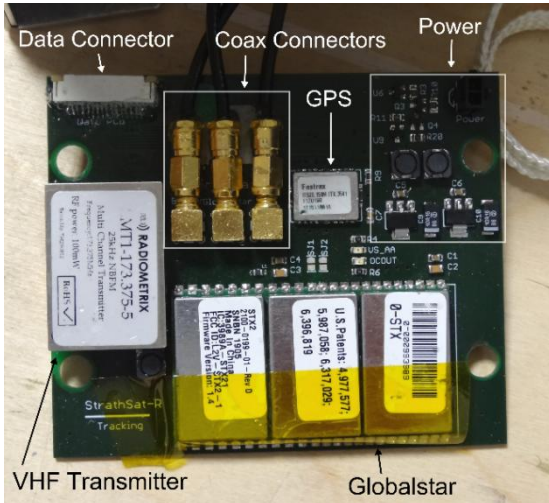

Figure 12: Tracking board

There is also a power PCB for power management in each of the ejectables which provides voltage rail regulation and battery charging. The electronics staying on-board the rocket require a different power PCB for power filtering and receiving the signals from the rocket's electrical interface.

IV.1 Tracking system and communications

There is no transmission of data from the ejectables to the rocket or ground after ejection due to the level of complexity involved and high data rates required for video. Therefore it is of critical importance to recover the experiment modules from the ground after they land. To ensure this, two key components are required; the parachute system described previously and the location system described here.

The location system was inspired by that used in the RAIN experiment [4]. After the parachute has been deployed, a GPS receiver is used to find the position of each module. This data is then transmitted to the ground in small packets using the Globalstar service. Additionally, the GPS position data is modulated over a VHF radio beacon. This signal can be used by the recovery team when in close proximity to the modules and will also be picked up by an antenna during the

parachute assisted descent. The Esrange Space Centre launch site makes use of a dish to point in the direction of the falling modules to detect the signals during their descent.

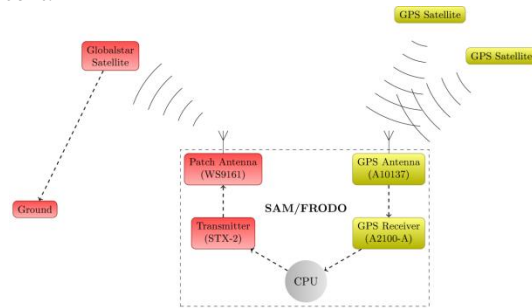

Figure 13: Architecture of the GPS data relay of the ejectables once the parachute is deployed.

The GPS relay system is designed with two distinct sections, as seen in Figure 13. These are the downlink, or GPS receiver, and the uplink or the transmission to Globalstar and over the VHF beacon. The downlink section uses a GPS receiver to obtain the current longitude and latitude and interface this to the microcontroller. The uplink section consists of two parts, a satellite communication service (Globalstar), and a VHF transmitter. The satellite link allows reliable location data to be sent from any location. The VHF transmitter provides a back-up location transmission and serves as a close proximity beacon for improved location by the helicopter crew.

Globalstar Transmitter

In order to utilise the Globalstar network, the STX-2 simplex transmitter is used in combination with a WS9161 patch antenna. The STX-2 is a surface mounted module which transmits data packets using direct sequence spread spectrum techniques implemented by modulating data with a pseudorandom noise sequence. It employs the CDMA air interface popularly used by mobile phones. The module sends 255 chip PN sequences at a rate of 1.25Mcps (Mega chips per second) giving a nominal data rate of 100.04bps (bits per second). The 18 byte CRC checked packets have a data payload of 9 bytes in big endian format. However, this is mostly transparent to the programmer as the module is interfaced over conventional serial with the physical layer hidden. The transmitter has an output power of 18dBm and delivers an error vector magnitude of less than 15% RMS for 1020 symbols.

The STX-2 transmitter sends the GPS \$GPGGA sentence which contains the time and location among other information. To retrieve the data several options exist, information can be received over email, or accessed from their website.

The STX-2 transmitter requires a characteristic impedance PCB track of 50Ω for impedance matching between the transmitter and antenna. The coplanar waveguide shown below delivers the correct impedance with standard PCB material.

Globalstar Antenna

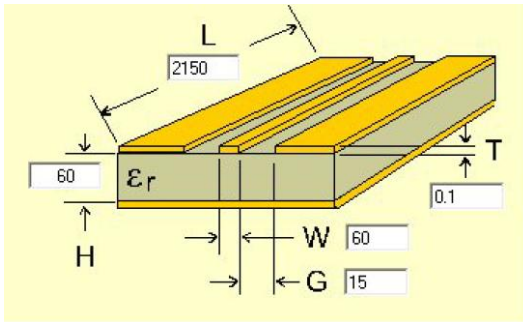

Figure 14: Suggested Ohm Trace Layout for STX-2

The WS9161 patch antenna is designed specifically to operate with the Globalstar communication network, with the key specifications of left hand circular polarisation centred at 1615 ± 5 MHz. This patch antenna was chosen over other similar antennas due to its reduced mass. The antenna is positioned in the same enclosure as the parachute; such that once the parachute is deployed the antenna will be orientated upwards.

Antenna gain is 3 dBic@90°, its 10dB return loss bandwidth is 25 MHz and the maximum transmit power is 21.5 dBm peak.

GPS Antenna

The Antenova A10137 antenna is a co-planar antenna designed primarily for mobile applications. It is a passive antenna, with an impedance of 50Ω , designed to receive signals of 1575MHz, the standard GPS signal frequency. It makes use of a pre-designed reference board with an integrated ground plane to ensure reliable operation. The reference board and antenna have dimensions of 20 x 60 mm.

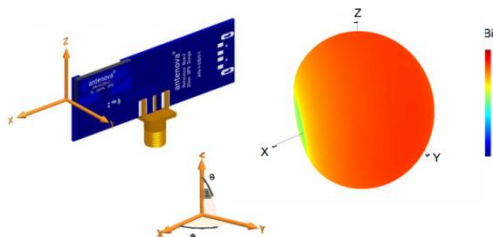

Figure 15 – Antenova Antenna Pattern (RHCP)

GPS Module

The Fastrax IT520 GPS module was chosen due to its very low power consumption, typically drawing only

75mW at 3V when in use. It is capable of surviving and operating in temperatures between -40°C and $+85^{\circ}\text{C}$, although the time required for a satellite fix at low temperatures may be longer than normal. It has a small surface mount footprint of $14.0 \times 10.4\text{mm} \times 2.3\text{mm}$.

The GPS position data is sent to the microcontroller over standard TTL UART in the NMEA GPS format. Information is sent in interpreted sentences prefixed with a sentence code allowing easy parsing of the data. In practise only the \$GPGGA sentence was needed as this contains the time, latitude, longitude, altitude and the number of satellites that are currently in view. The sentences are sent once a second which is a very suitable update rate given the relatively slow lateral movement of the experiment.

The simple push nature of data into the microcontroller’s UART allows extremely fast integration in software by polling of the UART buffer whenever position data is needed.

VHF Module

LMT1 transmitters are available in a variety of frequencies and Radiometrix is happy to deliver custom frequencies such as the 173.350 MHz and 173.375 MHz variants that were used. LMT1 has a nominal power output of 100mW and range of over 1 km. The beacon’s carrier is frequency modulated by a serial interface; phase modulation can also be achieved by capacitive coupling of the serial input.

Helical Antenna for RF Beacon

Considering the design recommendations given in the LMT1 datasheet, and the fact that a whip antenna would be difficult to orient at impact and therefore is prone to grounding loss, a helical antenna has been chosen for use with the RF beacon. This will be mounted below the parachute hatch to ensure final orientation and exposure to the sky (possibly through the parachute material depending on how the material is spread at landing).

The antenna will be mounted on its side to allow it to fit into the CubeSat-like module. After deployment of the parachute, the antenna will spring upright allowing a good transmission position. The spring capability is provided by a portion of measuring tape, as discussed previously.

IV.II Tracking Board

The three modules are all housed on a single two layer PCB. There is a power connector which supplies 5V nominal from the power PCB. Switching P-type MOSFETs are used to allow the tracking section to be switched on and off. During the launch there is a strict requirement that no RF transmission should be made in case it causes an unplanned ignition of the rocket. The power to RF modules is switched on after the parachute

has been deployed. Globalstar and GPS transmitters and receivers are also switched off once a location lock has been found and relayed to the satellites to prolong the battery life for the VHF transmitter.

There are two linear regulators to supply 3.3V analogue and digital power rails. Shielded inductors are used to isolate each of the components to prevent any noise being transferred onto the power rails. The LMT1 transmitter is powered directly from the 5V supply to provide more power for increased transmission distances.

The data connection is made with a 16 contact FFC (Flexible Flat Cable) connector.

V. SOFTWARE

Once the appropriate pressure has been detected indicating the correct altitude the parachute is deployed. Shortly after this the software enters the tracking section which is relatively simple.

The NMEA data is read from the GPS module and a simple filter for the characters "\$GPGGA" is implemented. All characters until the next "\$" are then relayed over serial to both the Globalstar and VHF beacon modules.

V. ACKNOWLEDGEMENTS

The authors would like to thank the German Aerospace Center (DLR), the Swedish National Space Board (SNSB), the European Space Agency (ESA), the Swedish Space Corporation (SSC) and everyone involved in REXUS/BEXUS for their support and for giving us the opportunity to fly our experiments.

We also would like to thank Bartels Mikrotechnik GMBH for offering us micro pumps at a reduced list price.

We are also very grateful to James Dorothy from the Mechanical Workshop of the University of Strathclyde for his support and pointing us to the right person to talk to at the University of Strathclyde. A big thank you goes as well to Tom McCanny of the Physics workshop for letting us use the vacuum chamber for our inflation and validation tests.

Finally, we take the chance to also thank our supervisors Colin McInnes, Malcolm Macdonald, Derek Bennet and Massimiliano Vasile for their continuous support of the experiment.

VI. CONCLUSIONS

This paper presents a detailed mechanical and electrical subsystem design description for lateral ejection and recovery of two CubeSat-like modules to be used in sounding rockets of the REXUS family. The design presented in this paper enables a payload volume of more than 40% of the original one unit CubeSat volume. The compressed spring – steel wire – pyro-

cutter ejection system is reliable and proved itself during multiple tests in the lab. Furthermore the recovery system of parachute, GPS receiver, Globalstar and radio beacon proved itself during the REXUS13 test flight and will be thoroughly validated before the REXUS15/16 launch in March 2014. Overall it can be said that by using the presented ejection and recovery system, the experiment team can focus on more important parts of the experiment, the payload.

REFERENCES

- ¹NASA, "NASA Sounding Rocket Program Handbook", 810-HB-SRP, Goddard Space Flight Centre, Wallops Flight Facility, Wallops Island, Virginia, June 2005
- ²Fittock, M., Stamminger, A., Maria, R., Dannenberg, K., and Page, H., "REXUS/BEXUS: launching student experiments-a step towards a stronger space science community." 38th COSPAR Scientific Assembly, Bremen, Germany, 18-25 July 2010, p. 6.
- ³Sinn, T., McRobb, M., Wujek, A., Skogby, J., Rogberg, F., Zhang, J., Tibert, G., Vasile, M., "Results of REXUS12'S Suaineadh Experiment: Deployment of a Spinning Space Web in Micro Gravity", IAC-12-A2.3.15, 63rd International Astronautical Congress (IAC), Naples, Italy, 1-5 October 2012
- ⁴Reid, W., Achtert, P., Ivchenko, N., Magnusson, P., Kuremyr, T., Shepenkov, V., and Tibert, G., "A novel rocket-based in-situ collection technique for mesospheric and stratospheric aerosol particles." Atmospheric Measurement Techniques Discussions 5, no. 6 (2012): 8161-8187.
- ⁵Edling Fidjeland, L., "GPS Experiment construction and analysis for the MUSCAT." PhD diss., KTH, 2012.
- ⁶Clark, R., Sinn, T., Lücking, C., Donaldson, N., Brown, R., Parry, T., Dolan, I., Lowe, C., Bewick, R., "StrathSat-R: Deploying Inflatable Cubesat Structures in Micro Gravity", IAC-12-E2.3.7, 63rd International Astronautical Congress (IAC), Naples, Italy, 1-5 October 2012
- ⁷Edling Fidjeland, L., "GPS Experiment construction and analysis for the MUSCAT." PhD diss., KTH, 2012.